

**Supplementary materials, *Dichotomius satanas*** (Coleoptera: Scarabaeidae, Scarabaeinae) of the cloud forest in eastern Mexico, by Julliana Barretto, Magdalena Cruz, and Federico Escobar. 2020. *The Canadian Entomologist*.

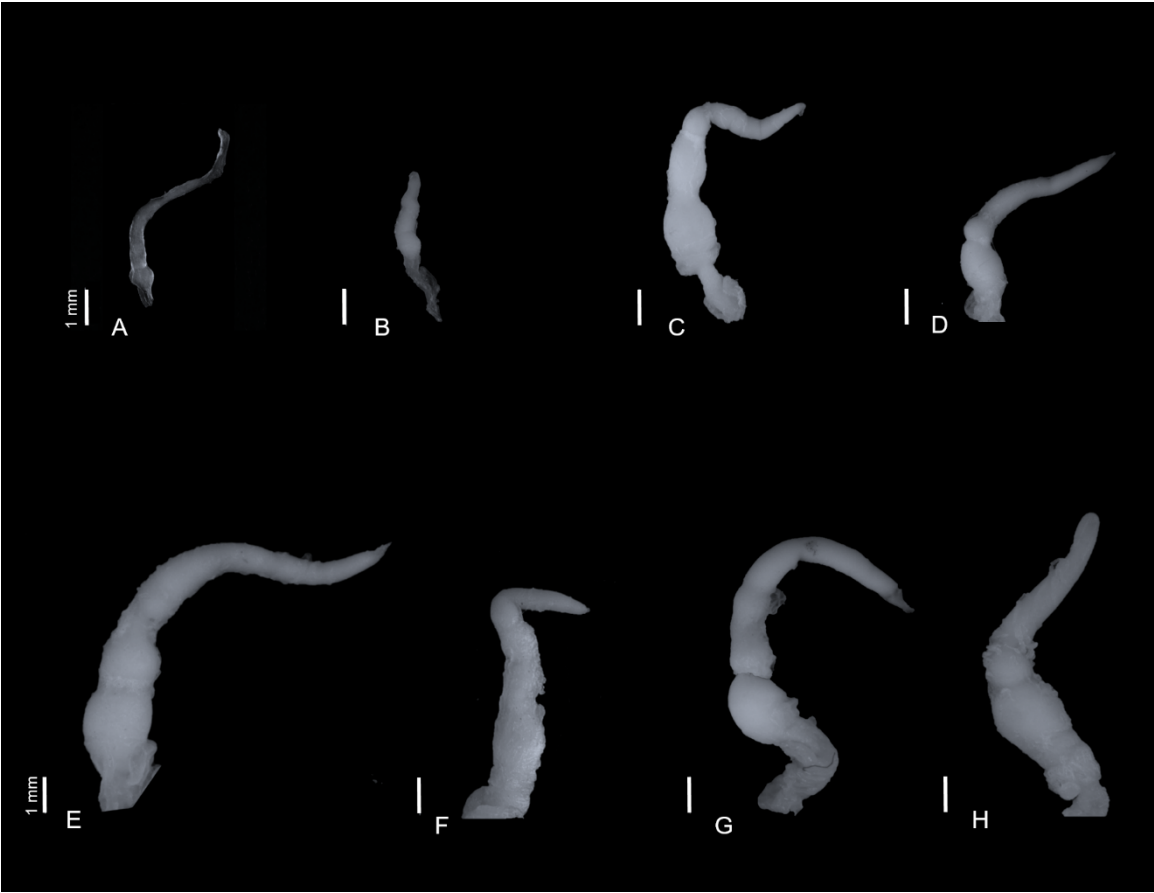

**Fig. S1.** Female ovaries of *Dichotomius satanas* captured between October 2015 and September 2016 in a cloud forest in Veracruz, Mexico. **A**, Ovary with basal oocyte absent; **B–H**, Variation of basal oocyte length.

Female

Predictor	%IncMSE	IncNodePurity
BF	20.88	9.85
BOC	8.95	3.16
IC	-2.58	2.65

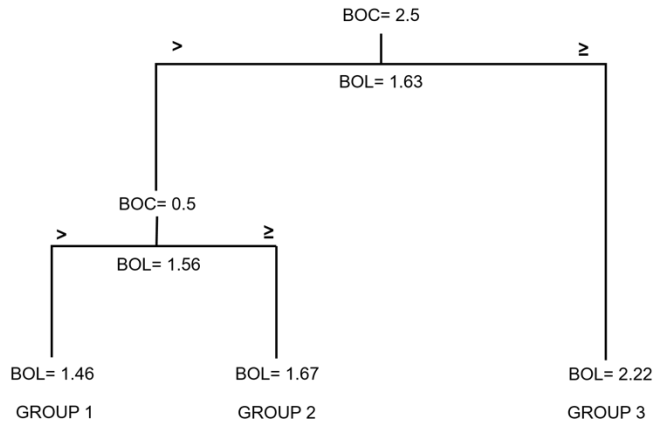

Male

Predictor	IncMSE	IncNodePurity
BF	17.66	19.93
IC	16.51	19.07

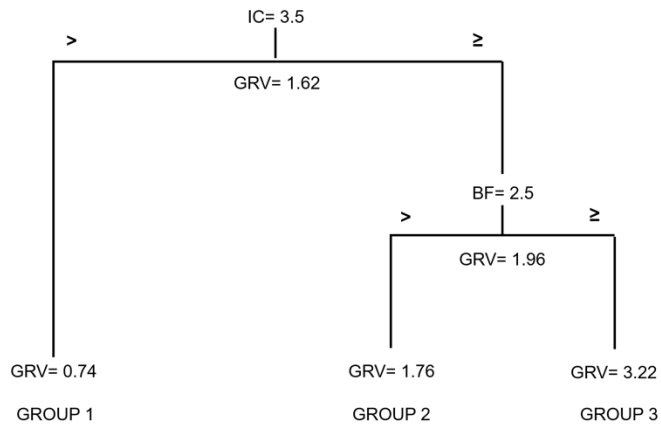

**Fig. S2.** Regression analysis trees of maturation states (immature, maturing, and mature) for *Dichotomius satanas* females and males, generated by the Random Forest Algorithm (Breiman 2001). The groups were formed considering the basal oocyte length (mm) and the glandular reservoir volume (mm<sup>3</sup>) in females and males, respectively. The explanatory variables (predictors) considered were: body fat content (BF), intestinal content (IC), and basal oocyte color (BOC). Each of the tree splits (nonterminal nodes) is labelled with the variable and the values that determine the split. The terminal nodes were labelled with the split value of the basal oocyte length (BOL) and the glandular reservoir volume (GRV) for females and males, respectively. For both trees, the *importance* (%IncMSE and IncNodePurity) of each predictor is shown for the consensus tree.

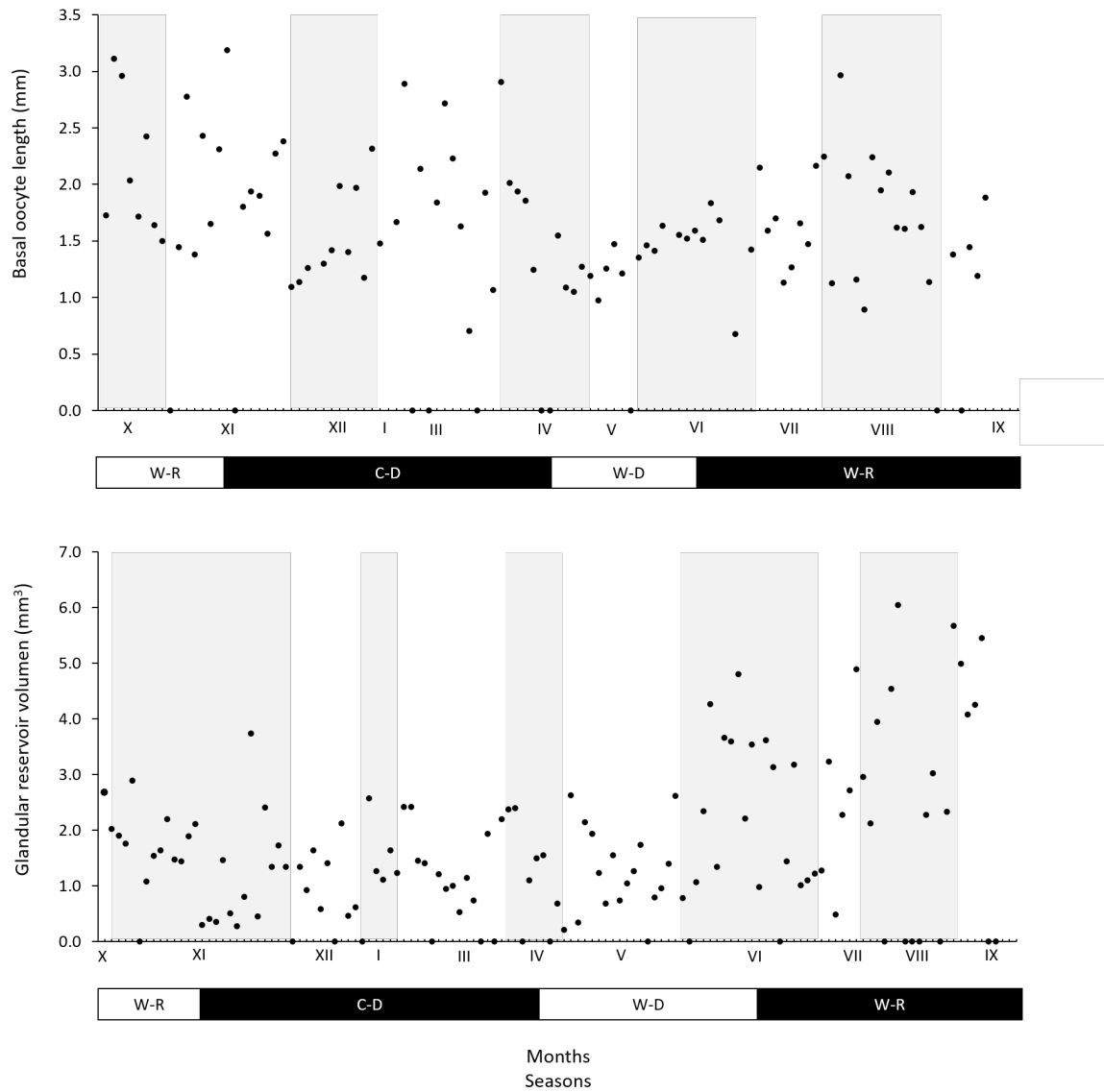

**Fig. S3.** Annual variation of basal oocyte length for females and glandular reservoir volume for males of *Dichotomius satanas* captured between October 2015 and September 2016 in a cloud forest in Veracruz, Mexico. Seasons: warm-rainy (W-R), cold-dry (C-D), and warm-dry (W-D).

**Table S1.** Generalized linear models (GLM) with a Poisson distribution for evaluating the relationship between the abundance of *Dichotomius satanas* and monthly temperature (maximum, mean, and minimum) and monthly precipitation recorded between October 2015 and September 2016 in a cloud forest in Veracruz, Mexico. The models considered abundance of all captured individuals (females + males), only female, and only male, according to maturation states (immature, maturing, and mature). Selected models are in bold font. Total<sub>AB</sub> = Total abundance (female + male). Maturation states: IM = immature; MG = maturing; M = mature. T<sub>max</sub> = maximum temperature; T<sub>mean</sub> = mean temperature; T<sub>min</sub> = minimum temperature; P = precipitation.

Abundance	Maturation states	Variable	Model	P-Shapiro	P	AICc	
All individuals (females + males)	All	Temperature	Null			149	
			GLM (Total <sub>AB</sub> ~ Tmax)	0.93	0.54	51	
			GLM (Total <sub>AB</sub> ~ Tmean)	0.99	0.0003	138	
			GLM (Total <sub>AB</sub> ~ Tmin)	0.71	< 0.0	122	
		Precipitation	GLM (Total <sub>AB</sub> ~ P)	0.49	< 0.0	122	
	Temperature + Precipitation	<b>GLM (Total<sub>AB</sub> ~ Tmin + P)</b>	<b>0.94</b>	<b>&lt; 0.0</b>	<b>120</b>		
	Immature	Temperature	Null			116	
			GLM (IM ~ Tmax)	0.61	0.38	118	
			GLM (IM ~ Tmean)	0.16	0.33	118	
			GLM (IM ~ Tmin)	0.28	0.01	112	
		Precipitation	GLM (IM ~ P)	0.51	0.008	112	
	Temperature + Precipitation	<b>GLM (IM ~ Tmin + P)</b>	<b>0.18</b>	<b>&lt; 0.0</b>	<b>114</b>		
	Maturing	Temperature	Null			77	
			GLM (MG ~ Tmax)	0.58	0.57	80	
			GLM (MG ~ Tmean)	0.78	0.001	69	
		Precipitation	<b>GLM (MG ~ Tmin)</b>	<b>0.41</b>	<b>0.0006</b>	<b>65</b>	
	Mature	Temperature	Modelo Null			65	
			GLM (M ~ Tmax)	0.17	0.33	67	
			GLM (M ~ Tmean)	0.93	0.004	58	
			GLM (M ~ Tmin)	0.62	0.002	55	
		Precipitation	<b>GLM (M ~ P)</b>	<b>0.30</b>	<b>&lt; 0.0</b>	<b>50</b>	
	Females	Immature	Temperature	Null			62
				GLM (IM ~ Tmax)	0.50	0.11	62
				GLM (IM ~ Tmean)	0.33	0.16	63
			Precipitation	<b>GLM (IM ~ Tmin)</b>	<b>0.18</b>	<b>0.01</b>	<b>58</b>
Maturing		Temperature	GLM (IM ~ P)	0.90	0.08	62	
			Null			58	
			GLM (MG ~ Tmax)	0.42	0.45	60	
		Precipitation	GLM (MG ~ Tmean)	0.39	0.01	54	
Mature		Temperature	<b>GLM (MG ~ Tmin)</b>	<b>0.42</b>	<b>0.004</b>	<b>50</b>	
			GLM (MG ~ P)	0.14	0.06	58	
			Null			49	
			GLM (M ~ Tmax)	0.01	0.09	49	
		Precipitation	GLM (M ~ Tmean)	0.01	0.44	51	
Males	Immature	Temperature	GLM (M ~ Tmin)	0.01	0.40	51	
			GLM (M ~ P)	0.02	0.31	51	
			Null			98	
		Precipitation	GLM (IM ~ P)	<b>0.21</b>	<b>0.04</b>	<b>97</b>	
Maturing	Temperature	Null			55		
		GLM (MG ~ Tmax)	0.53	0.98	58		
		GLM (MG ~ Tmean)	0.99	0.06	54		
		GLM (MG ~ Tmin)	0.98	0.05	53		
		Precipitation	<b>GLM (MG ~ P)</b>	<b>0.27</b>	<b>0.001</b>	<b>48</b>	
		Mature	Temperature	Null			53
	GLM (M ~ Tmax)		0.002	0.77	56		
Mature	Temperature	GLM (M ~ Tmean)	0.81	0.005	39		
		GLM (M ~ Tmin)	0.96	0.001	30		
		Precipitation	GLM (M ~ P)	0.007	< 0.0	30	
	Temperature + Precipitation	<b>GLM (M ~ Tmin + P)</b>	<b>0.05</b>	<b>0.01</b>	<b>25</b>		

**Table S2.** Results of analysis of deviance (type II test) and Turkey test of contrasts obtained from the selected generalised linear model (interacted model) with a Poisson distribution for evaluating the effect of the state of maturation (immature, maturing, and mature) and sex on the abundance of the individuals of *Dichotomius satanas* captured between October 2015 and September 2016 in a cloud forest in Veracruz, Mexico. Bold text indicates statistically significant differences.

Analysis of deviance table.

Variable	<i>Chi</i> <sup>2</sup>	df	P
<b>State of maturation</b>	<b>62.876</b>	<b>2</b>	<b>&lt; 0.0001</b>
Sex	2.598	1	0.10699
<b>State of maturation: Sex</b>	<b>10.232</b>	<b>2</b>	<b>0.0060</b>

Tukey test contrast.

State of maturation / sex	Estimate	Std. Error	Z-value	P (> z )
Maturing male vs Maturing female	0.34093	0.23124	1.474	0.66879
Immature female vs Maturing female	0.04349	0.20856	0.208	0.99994
<b>Immature male vs Maturing female</b>	<b>0.62415</b>	<b>0.18473</b>	<b>3.379</b>	<b>0.00895</b>
<b>Mature female vs Maturing female</b>	<b>1.03407</b>	<b>0.29107</b>	<b>3.553</b>	<b>0.00490</b>
<b>Mature male vs Maturing female</b>	<b>0.97345</b>	<b>0.28469</b>	<b>3.419</b>	<b>0.00782</b>
Immature female vs Maturing male	0.38441	0.22919	1.677	0.53336
<b>Immature male vs Maturing male</b>	<b>0.96508</b>	<b>0.20774</b>	<b>4.646</b>	<b>&lt; 0.001</b>
Mature female vs Maturing male	0.69315	0.30619	2.264	0.19941
Mature male vs Maturing male	0.63252	0.30012	2.108	0.27167
<b>Immature male vs Immature female</b>	<b>0.58067</b>	<b>0.18216</b>	<b>3.188</b>	<b>0.01687</b>
<b>Mature female vs Immature female</b>	<b>1.07756</b>	<b>0.28944</b>	<b>3.723</b>	<b>0.00255</b>
<b>Mature male vs Immature female</b>	<b>1.01693</b>	<b>0.28302</b>	<b>3.593</b>	<b>0.00411</b>
<b>Mature female vs Immature male</b>	<b>1.65823</b>	<b>0.27277</b>	<b>6.079</b>	<b>&lt; 0.001</b>
<b>Mature male vs Immature male</b>	<b>1.59760</b>	<b>0.26595</b>	<b>6.007</b>	<b>&lt; 0.001</b>
Mature male vs Mature female	0.06062	0.34832	0.174	0.99998